

A photograph of an Ammann ARX 12 Tandem Roller in operation on a road construction site. The machine is light green and yellow, with a driver wearing a yellow hard hat and safety gear. The background shows a clear blue sky and a power line tower. A large teal graphic overlay is on the left side of the image.

ARX 12

LIGHT TANDEM VIBRATORY ROLLER
EU Stage V / US EPA Tier 4f

PERFORMANCE ON THE EDGES

The Ammann ARX 12 Tandem Roller is a light, articulated ride-on roller that works flush against curbs and other obstructions and eliminates the need for special edge compaction efforts. Double-drive and double-vibration are standard and help deliver optimum compaction results.

An electronic drive-lever makes for smooth starting and stopping and is among the reasons the roller is popular with operators.

PRODUCTIVITY

Electronic drive lever
Smooth start and stop important, especially on asphalt jobs

Articulated joint with oscillation
Increased surface coverage and quality

Sprinkling system
2-stage filtration system with large water tanks for extended intervals between fillings

ERGONOMICS

Operators platform design
Spacious operator platform

Simple and reliable dashboard
Intuitive machine control, even with an unskilled operator

Visibility
Perfect all-around machine visibility for safety on the jobsite

SERVICEABILITY

Design that enables daily maintenance
Easy and fast daily maintenance

Accessible service and maintenance points
Machine serviced from ground, enabling comfort

Maintenance free parts
Reduced risk of machine damage

APPLICATIONS

- Small and medium construction sites
- City roads
- Boardwalks
- Repair works in city centre

AMMANN

TECHNICAL SPECIFICATIONS
ARX 12 LIGHT TANDEM VIBRATORY ROLLER
EU Stage V / US EPA Tier 4f

DIMENSIONS

A	MACHINE LENGTH	2020 mm (79.5 in)
B	WHEELBASE	1440 mm (56.7 in)
C	MACHINE HEIGHT	2400 mm (94.5 in)
D	MACHINE HEIGHT (FOLDED ROPS)	1730 mm (68.1 in)
E	DRUM WIDTH	820 mm (32.3 in)
E	TIRE-AXLE WIDTH	-
F	MACHINE WIDTH	870 mm (34.3 in)
G	MACHINE LENGTH	2220 mm (87.4 in)
H	GROUND CLEARANCE	230 mm (9.1 in)
I	DRUM DIAMETER	580 mm (22.8 in)
J	DRUM SHELL THICKNESS	13 mm (0.5 in)
K	MACHINE WIDTH (TOTAL)	870 mm (34.3 in)
L	MACHINE LENGTH (FOLDED ROPS)	2330 mm (91.7 in)

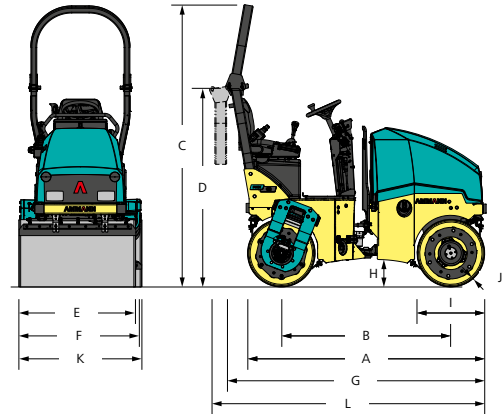

COMPACTION FORCES

AMPLITUDE	0.5 mm (0.02 in)
FREQUENCY AT 2100 / 2400 RPM	58/66 Hz (3480/3960 VPM)
CENTRIFUGAL FORCE	19/22 kN

MISCELLANEOUS

BATTERY / CAPACITY	12/77 V/Ah
WATER TANK	110 l (29.1 gal)
HYDRAULIC SYSTEM	28.5 l (7.5 gal)
DIESEL FUEL TANK	24 l (6.3 gal)
WHEEL LOAD	-
NUMBER OF WHEELS	-
TIRE SIZE	-

ENGINE

ENGINE TYPE	YANMAR 3TNV80F
EMMISSION CLASS	EU Stage V / US EPA Tier 4f
POWER OUTPUT ISO 3046	14.6 kW /20 HP
CYLINDER / LTR.	3 cyl / 1267 No./ccm
1. / 2. WORKING SPEED	2.100 / 2.400 rpm
TRAVEL SPEED KM/H	8.5 km/h (5.3 MPH)
GRADEABILITY WITH / WITHOUT VIBR.	30 % / 40 %

WEIGHT & OPERATING CHARACTERISTICS

OPERATING WEIGHT CECE	1460 kg (3220 lb)
OPERATING WEIGHT MAX.	1700 kg (3750 lb)
STATIC LINEAR LOAD (FULL-FLUSH)	8.4/9.4 kg/cm (18.5/20.7 lb)
TURNING RADIUS INSIDE	2100 mm (82.7 in)
STEERING / OSCILLATING ANGLE	30/6 ±°
DRUM OFFSET	50 mm (1.97 in)



STANDARD

- Front and rear vibration and drive
- Control system with emergency stop
- Pressurised pulse interval sprinkler system
- Ammann Vibration Control
- Central lifting hook
- 2 working frequencies
- Hydraulic test ports

OPTIONAL EQUIPMENT

- CE-Kit with folding ROPS and working lights
- Road lighting
- Canopy
- Asphalt thermometer
- Reverse alarm
- Battery disconnection switch
- Additional working lights (ROPS mounted)
- Arm rests
- Second drive-lever, left
- Edge-cutter incl. multi-function lever
- Bio-degradable hydraulic oil
- Drums in line
- Customer colour
- Warning beacon
- Weather canopy